

- 1 BLK/BRN
- 2 BLK/YEL
- 3 WHT/YEL
- 4 BLU/YEL

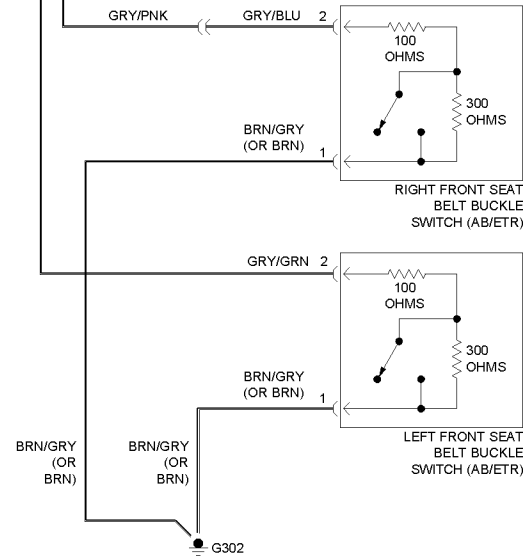

SHORTING BAR	43	JUMPERED BETWEEN PINS 15 & 16
SHORTING BAR	44	JUMPERED BETWEEN PINS 17 & 18
SHORTING BAR	45	JUMPERED BETWEEN PINS 19 & 20
SHORTING BAR	46	JUMPERED BETWEEN PINS 21 & 22
SHORTING BAR	47	JUMPERED BETWEEN PINS 23 & 24
SHORTING BAR	48	JUMPERED BETWEEN PINS 25 & 26
SHORTING BAR	49	JUMPERED TO PIN 27
SHORTING BAR	50	JUMPERED TO PIN 28
SHORTING BAR	51	
SHORTING BAR	52	
SHORTING BAR	53	
SHORTING BAR	54	
SHORTING BAR	55	
SHORTING BAR	(UN-NUMBERED PIN)	
SHORTING BAR	(UN-NUMBERED PIN)	
	56	
	57	ETR, D+
	58	ETR, D-
	59	ETR, P-
	60	ETR, P+
	61	ACSR LED
	62	ACSR
	63	SENSOR P
	64	SENSOR D
	65	ETR, LR+
	66	ETR, LR-
	67	ETR, RR+
	68	ETR, RR-
	69	D+
	70	P+

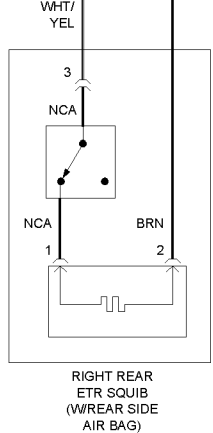
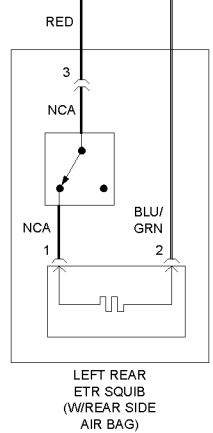
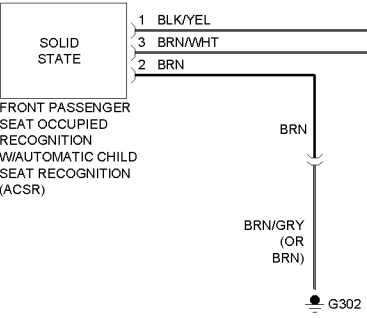